

承认书

SPECIFICATION FOR APPROVAL

编号:

客户	CUSTOMER :	_____
制造商料号	P/N :	HRS-F31L-1A7H1- 110XX
客户料号	CUSTOMER P/N :	_____
规格	SPEC :	0.5Pitch FPC Connector
包装	PACKAGE :	卷装
日期	DATE :	2021-2-1

APPROVED BY

CUSTOMER

Horustech

This document is the property of Horustech Corporation and is delivered on the express condition that it is not to be disclosed, reproduced or used, in whole or in part, for manufacture or sale by anyone other than Horustech Corporation without its prior consent, & that no right is granted to disclose or to use any information in this document.

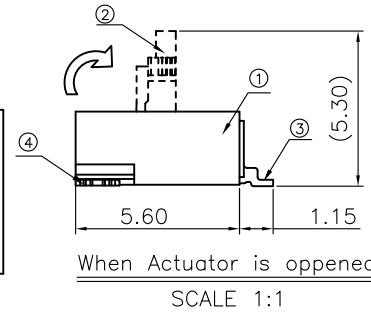
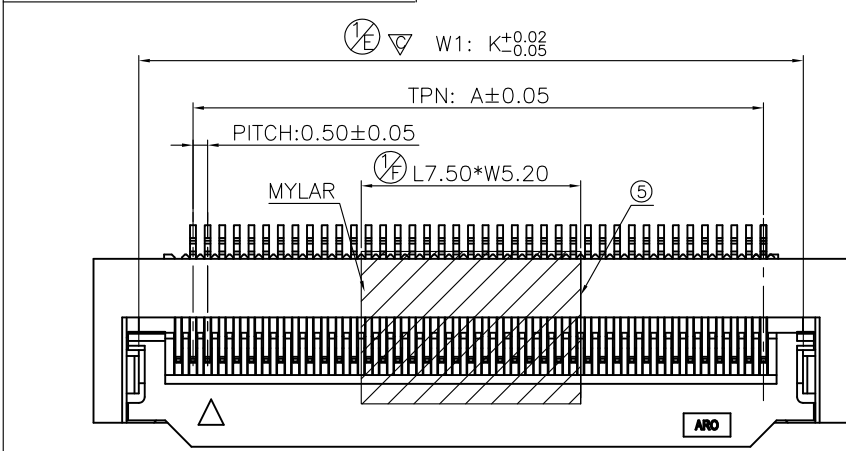

SPECIFICATION
 1. CONTACT RESISTANCE : 30mΩ MAX.;
 2. DIELECTRIC WITHSTANDING VOLTAGE;
 500V AC R.M.S. FOR 1 MINUTE;
 3. INSULATION RESISTANCE : 500MΩ MIN;
 4. "▼" IS IMPORTANT DIMENSION;
 5. "▽" NOTATION FOR CPK AND X-R TEST SIZE
 6. ALL MATERIAL MUST BE COMPLY WITH SS-00259 OR RoHS.
 7. PART NO.:

HRS-F31L-1*7*1-110**(WITH MYLAR) NO. OF POSITIONS
 HRS-F31L-1*7*1-110**-E110(升级料号)

1A:LCP Natural 7H:PHOSPHOR BRONZE
 1B:LCP Black 0.05um MIN Au(Au Area)
 7A:PHOSPHOR BRONZE
 MATTER TIN

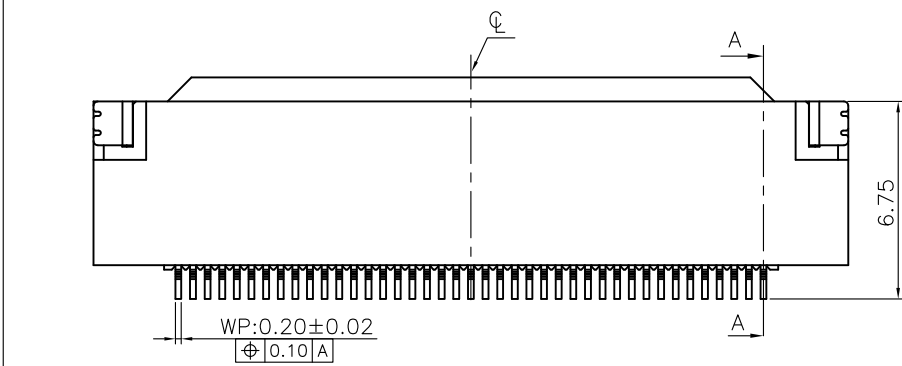
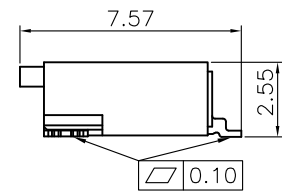
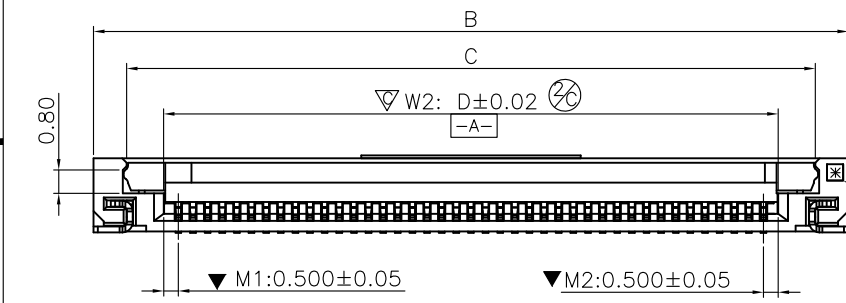
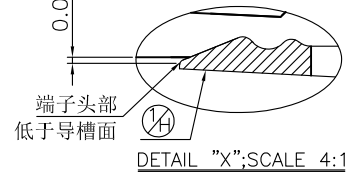
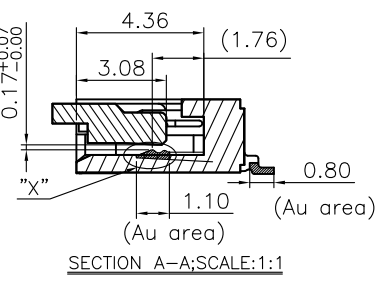

NO.	COMPONENTS	MATERIALS	FINISH/COLOR SPECIFICATION	QTY.
1	HOUSING	Liquid crystal polymer	Natural or Black(UL94V-0);	1
2	ACTUATOR	Polyamide 9T	black(UL94V-0);	1
3	CONTACT	Phosphor Bronze T=0.20mm	UNDER PLATING:1~3um Ni SURFACE SELECT PLATING:SEE PART NO.	N
4	ANCHOR-PLATE	Brass T=0.20mm	2~4 um Tin PLATING 1~3 um Ni UNDERPLATING	2
5	MYLAR	T=0.10mm THERMOSTABLE	YELLOW	1

UNLESS OTHERWISE SPECIFIED TOLERANCES		ANGLE OF PROJECTION		
X.	±0.50	X. °	± 1°	
X.X	±0.25	X.X °	± 0.5°	
X.XX	±0.15	X.XX °	± 0.5°	
X.XXX	±0.10	X.XXX °	± 1°	
LINEAR DIMS		ANGLES DIMS		DOC TYPE: Customer Drw
P/N: HRS-F31L-1*7*1-110** HRS-F31L-1*7*1-110**-E110		DRAWN DATE: Sam 2016-05-15	DESIGN DATE: Sam 2016-05-15	TITLE: Assembly Drawing For 0.5mm pitch Front side filp, with lock,H2.55mm(4~40PIN)
MATERIAL	SEE NOTES	CHECKED DATE: Jason 2016-05-15	APPROVED DATE: Frank 2016-05-15	SIZE: A4 DWG NO. A-S0099 REV. I
FINISHED	SEE NOTES	SCALE: 1:1 UNIT: mm SHEET 1 OF 2		

This document is the property of Horustech Corporation and is delivered on the express condition that it is not to be disclosed, reproduced or used, in whole or in part, for manufacture or sale by anyone other than Horustech Corporation without its prior consent, & that no right is granted to disclose or to use any information in this document.

1. FFC PATTERN DIMENSION

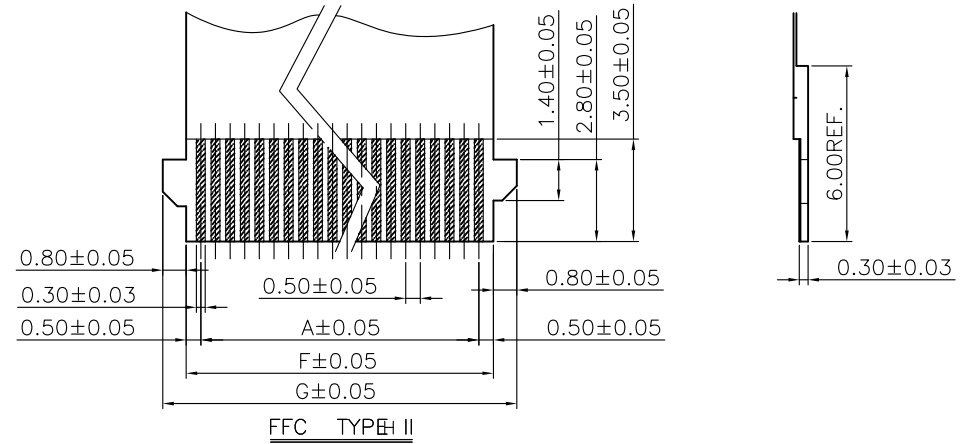
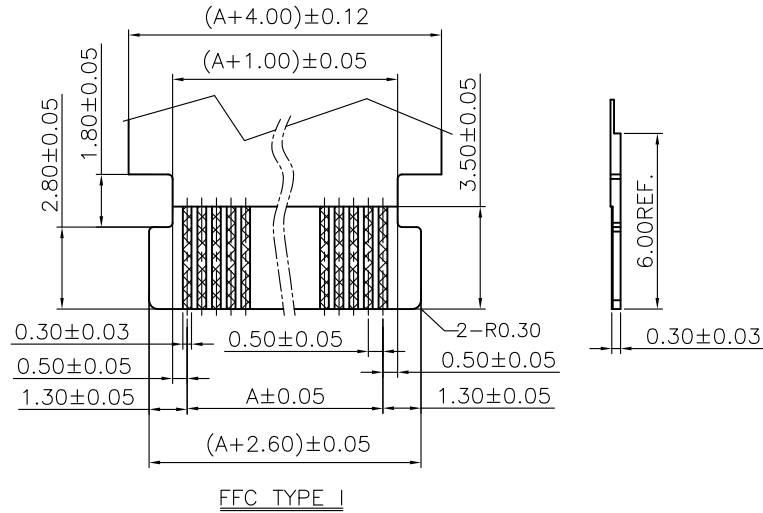

DIMENSION LIST:

NO. OF POS	A	B	C	D	F	G	J	K	NO. OF POS	A	B	C	D	F	G	H	J	K	
4	1.5	7.3	5.04	2.5	2.5	4.1	7.6	3.5	4.22	23	11.0	16.8	14.54	12.0	12.0	13.6	17.1	13.5	13.72
5	2.0	7.8	5.54	3.0	3.0	4.6	8.1	4.0	4.72	24	11.5	17.3	15.04	12.5	12.5	14.1	17.6	14.0	14.22
6	2.5	8.3	6.04	3.5	3.5	5.1	8.6	4.5	5.22	25	12.0	17.8	15.54	13.0	13.0	14.6	18.1	14.5	14.72
7	3.0	8.8	6.54	4.0	4.0	5.6	9.1	5.5	5.72	26	12.5	18.3	16.04	13.5	13.5	15.1	18.6	15.0	15.22
8	3.5	9.3	7.04	4.5	4.5	6.1	9.6	6.0	6.22	27	13.0	18.8	16.54	14.0	14.0	15.6	19.1	15.5	15.72
9	4.0	9.8	7.54	5.0	5.0	6.6	10.1	6.5	6.72	28	13.5	19.3	17.04	14.5	14.5	16.1	19.6	16.0	16.22
10	4.5	10.3	8.04	5.5	5.5	7.1	10.6	7.0	7.22	29	14.0	19.8	17.54	15.0	15.0	16.6	20.1	16.5	16.72
11	5.0	10.8	8.54	6.0	6.0	7.6	11.1	7.5	7.72	30	14.5	20.3	18.04	15.5	15.5	17.1	20.6	17.0	17.22
12	5.5	11.3	9.04	6.5	6.5	8.1	11.6	8.0	8.22	31	15.0	20.8	18.54	16.0	16.0	17.6	21.1	17.5	17.72
13	6.0	11.8	9.54	7.0	7.0	8.6	12.1	8.5	8.72	32	15.5	21.3	19.04	16.5	16.5	18.1	21.6	18.0	18.22
14	6.5	12.3	10.04	7.5	7.5	9.1	12.6	9.0	9.22	33	16.0	21.8	19.54	17.0	17.0	18.6	22.1	18.5	18.72
15	7.0	12.8	10.54	8.0	8.0	9.6	13.1	9.5	9.72	34	16.5	22.3	20.04	17.5	17.5	19.1	22.6	19.0	19.22
16	7.5	13.3	11.04	8.5	8.5	10.1	13.6	10.0	10.22	35	17.0	22.8	20.54	18.0	18.0	19.6	23.1	19.5	19.72
17	8.0	13.8	11.54	9.0	9.0	10.6	14.1	10.5	10.72	36	17.5	23.3	21.04	18.5	18.5	20.1	23.6	20.0	20.22
18	8.5	14.3	12.04	9.5	9.5	11.1	14.6	11.0	11.22	37	18.0	23.8	21.54	19.0	19.0	20.6	24.1	20.5	20.72
19	9.0	14.8	12.54	10.0	10.0	11.6	15.1	11.5	11.72	38	18.5	24.3	22.04	19.5	19.5	21.1	24.6	21.0	21.22
20	9.5	15.3	13.04	10.5	10.5	12.1	15.6	12.0	12.22	39	19.0	24.8	22.54	20.0	20.0	21.6	25.1	21.5	21.72
21	10.0	15.8	13.54	11.0	11.0	12.6	16.1	12.5	12.72	40	19.5	25.3	23.04	20.5	20.5	22.1	25.6	22.0	22.22
22	10.5	16.3	14.04	11.5	11.5	13.1	16.6	13.0	13.22										

2. P.C.B LAYOUT, TOL: ±0.05

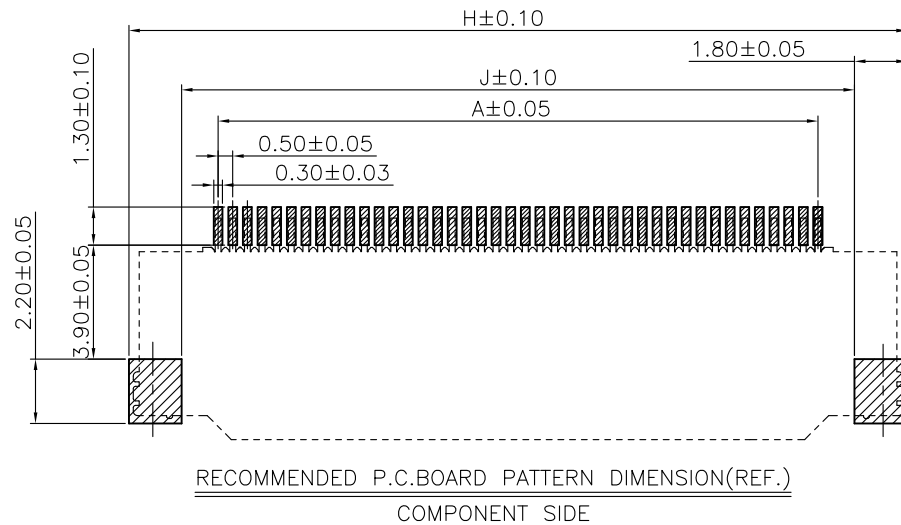

UNLESS OTHERWISE SPECIFIED TOLERANCES		ANGLE OF PROJECTION		
X.	±0.50	X.	± 1°	
XX	±0.25	XX	± 0.5°	
XXX	±0.15	XXX	± 0.5°	
X.XX	±0.10	X.XX	± 1°	
LINEAR DIMS		ANGLES DIMS		DOC TYPE: Customer Drw
P/N: HRS-F31L-17*1-110** HRS-F31L-17*1-110**E110		DRAWN DATE: Sam 2016-05-15		TITLE: Assembly Drawing For 0.5mm pitch Front side filp, with lock,H2.55mm(4~40PIN)
MATERIAL: SEE NOTES		DESIGN DATE: Sam 2016-05-15		SIZE: DWG NO. A4
FINISHED: SEE NOTES		CHECKED DATE: Jason 2016-05-15		REV. I
		APPROVED DATE: Frank 2016-05-15		SCALE: 1:1 UNIT: mm SHEET 2 OF 2

This document is the property of Horustech Corporation and is delivered on the express condition that it is not to be disclosed, reproduced or used, in whole or in part, for manufacture or sale by anyone other than Horustech Corporation without its prior consent, & that no right is granted to disclose or to use any information in this document.

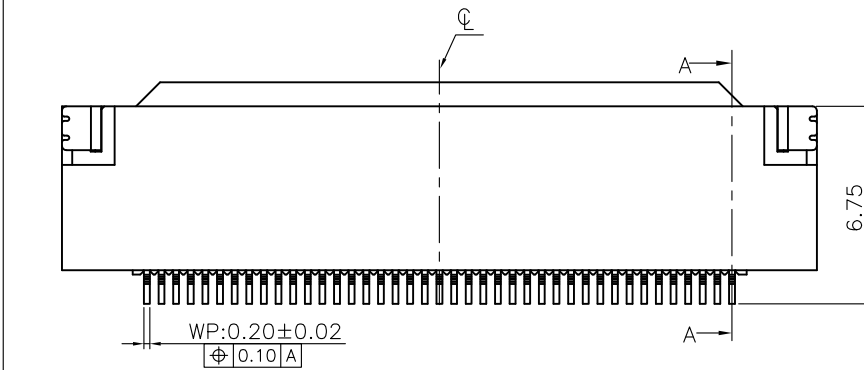
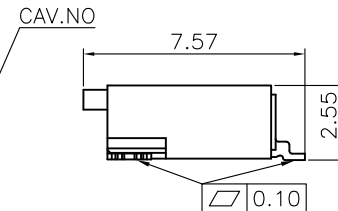
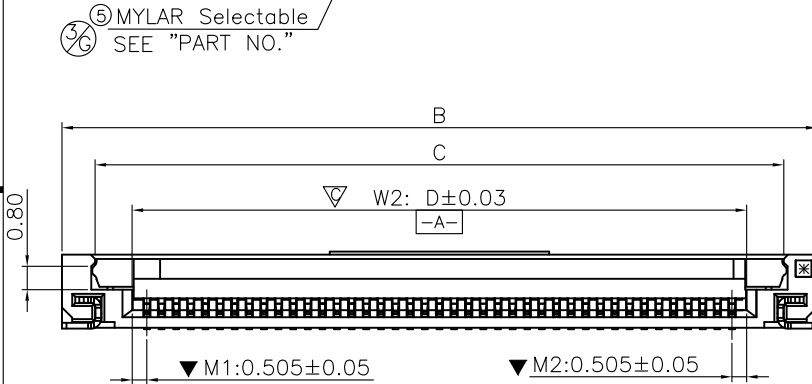
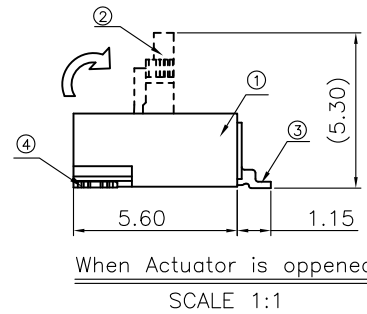
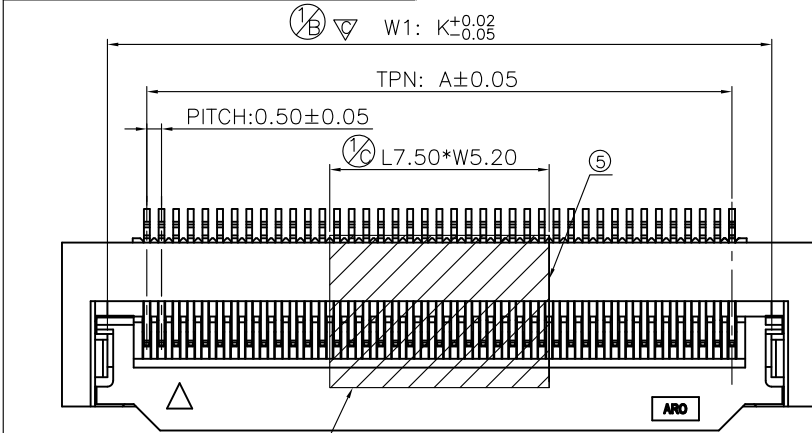

REV.	ECR/ECN No.	DESCRIPTION	DRAWN/DATE	CHECKED/DATE	APPROVED/DATE
E	/	改善皮线保持力, 端子头部形状变更	May 2016-04-13	Rain 2016-04-13	Hongkui.Liu 2016-04-13
F	/	客户要求料号升级	May 2016-05-13	Rain 2016-05-13	Hongkui.Liu 2016-05-13
G	/	新增规格PIN数	May 2017-03-27	Rain 2017-03-27	Hongkui.Liu 2017-03-27

SPECIFICATION

- CONTACT RESISTANCE : 30mΩ MAX.;
- DIELECTRIC WITHSTANDING VOLTAGE; 500V AC R.M.S. FOR 1 MINUTE;
- INSULATION RESISTANCE : 500MΩ MIN;
- "▽" IS IMPORTANT DIMENSION;
- "▽" NOTATION FOR CPK AND X-R TEST SIZE
- ALL MATERIAL MUST BE COMPLY WITH SS-00259 OR RoHS.
- PART NO.:

HRS-F31L-1*7*1-110**(WITH MYLAR)

HRS-F31L-1*7*1-110**-E*20(升级料号)

1:WITH MYLAR
2:WITHOUT MYLAR

1A:LCP Natural
1B:LCP Black
NO. OF POSITIONS
7H:PHOSPHOR BRONZE
0.05um MIN Au(Au Area)
7A:PHOSPHOR BRONZE
MATTER TIN

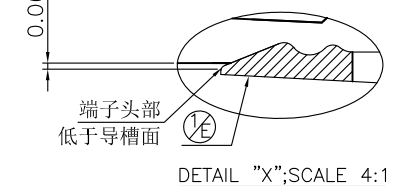
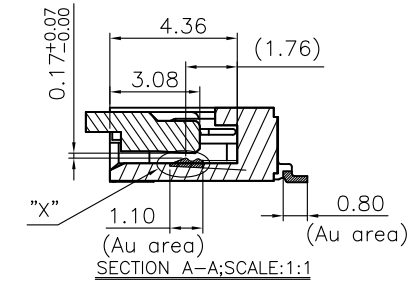

NO.	COMPONENTS	MATERIALS	FINISH/COLOR	SPECIFICATION	QTY.
1	HOUSING	Liquid crystal polymer	Natural or Black(UL94V-0);		1
2	ACTUATOR	Polyamide 9T	black(UL94V-0);		1
3	CONTACT	Phosphor Bronze T=0.20mm	UNDER PLATING:1~3um Ni SURFACE SELECT PLATING:SEE PART NO.		N
4	ANCHOR-PLATE	Brass T=0.20mm	2~4 um Tin PLATING 1~3 um Ni UNDERPLATING		2
5	MYLAR	T=0.10mm THERMOSTABLE	YELLOW		1

UNLESS OTHERWISE SPECIFIED TOLERANCES		
X.	±0.50	X. * ± 1'
X.X	±0.25	X.X * ± 0.5'
X.XX	±0.15	X.XX * ± 0.5'
X.XXX	±0.10	X.XXX * ± 1'

ANGLE OF PROJECTION	
Customer Drw	
DOC TYPE	Customer Drw
DRAWN	Sam
DATE	2017-03-27
DESIGN	Sam
DATE	2017-03-27
CHECKED	Jason
DATE	2017-03-27
APPROVED	Frank
DATE	2017-03-27

瑞澤電子股份有限公司
Horustech Electronics Co., Ltd

P/N:		MATERIAL		FINISHED		TITLE:		SCALE		UNIT		SHEET	
HRS-F31L-1*7*1-110** HRS-F31L-1*7*1-110**-E*20		SEE NOTES		SEE NOTES		Assembly Drawing For 0.5mm pitch Front side filp, with lock,H2.55mm(41~69PIN)		A4		mm		1 OF 2	
						DWG NO. A-S0083		1:1		mm		1 OF 2	

This document is the property of Horustech Corporation and is delivered on the express condition that it is not to be disclosed, reproduced or used, in whole or in part, for manufacture or sale by anyone other than Horustech Corporation without its prior consent, & that no right is granted to disclose or to use any information in this document.

1. FFC PATTERN DIMENSION

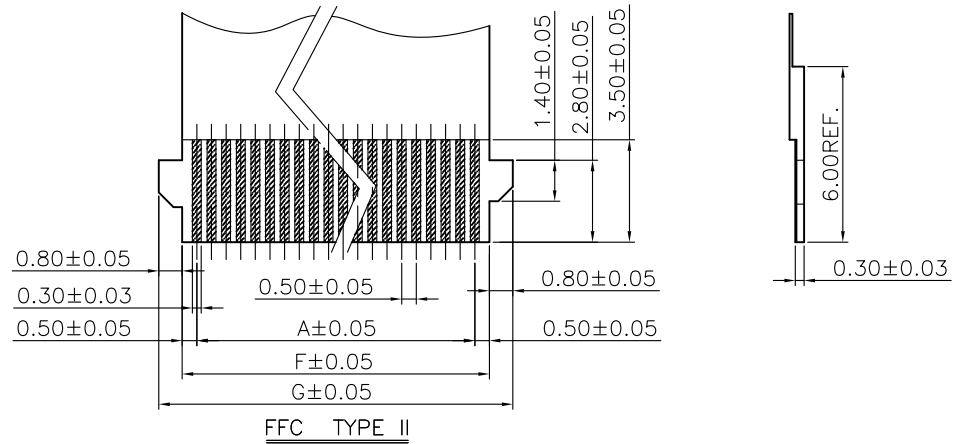
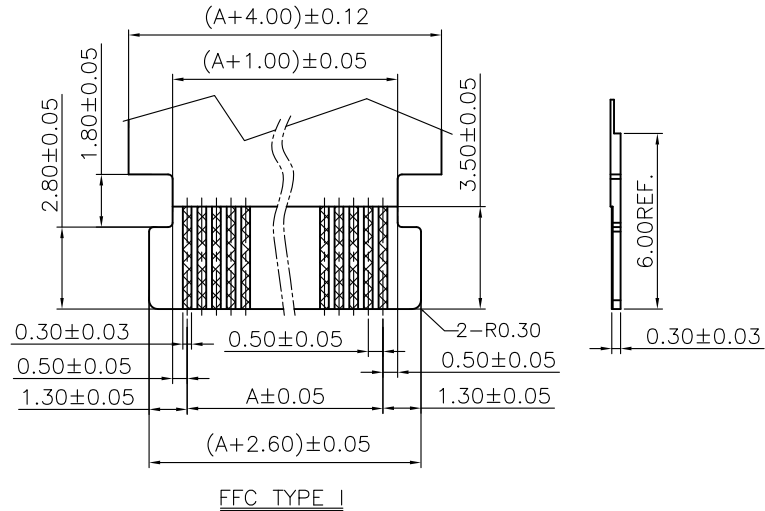

DIMENSION LIST:

NO. OF POS	A	B	C	D	F	G	H	J	K	NO. OF POS	A	B	C	D	F	G	H	J	K
41	20.0	25.8	23.54	21.01	21.0	22.6	26.1	22.5	22.72	56	27.5	33.3	31.04	28.51	28.5	30.1	33.6	30.0	30.22
42	20.5	26.3	24.04	21.51	21.5	23.1	26.6	23.0	23.22	57	28.0	33.8	31.54	29.01	29.0	30.6	34.1	30.5	30.72
43	21.0	26.8	24.54	22.01	22.0	23.6	27.1	23.5	23.72	58	28.5	34.3	32.04	29.51	29.5	31.1	34.6	31.0	31.22
44	21.5	27.3	25.04	22.51	22.5	24.1	27.6	24.0	24.22	59	29.0	34.8	32.54	30.01	30.0	31.6	35.1	31.5	31.72
45	22.0	27.8	25.54	23.01	23.0	24.6	28.1	24.5	24.72	60	29.5	35.3	33.04	30.51	30.5	32.1	35.6	32.0	32.22
46	22.5	28.3	26.04	23.51	23.5	25.1	28.6	25.0	25.22	61	30.0	35.8	33.54	31.01	31.0	32.6	36.1	32.5	32.72
47	23.0	28.8	26.54	24.01	24.0	25.6	29.1	25.5	25.72	62	30.5	36.3	34.04	31.51	31.5	33.1	36.6	33.0	33.22
48	23.5	29.3	27.04	24.51	24.5	26.1	29.6	26.0	26.22	63	31.0	36.8	34.54	32.01	32.0	33.6	37.1	33.5	33.72
49	24.0	29.8	27.54	25.01	25.0	26.6	30.1	26.5	26.72	64	31.5	37.3	35.04	32.51	32.5	34.1	37.6	34.0	34.22
50	24.5	30.3	28.04	25.51	25.5	27.1	30.6	27.0	27.22	65	32.0	37.8	35.54	33.01	33.0	34.6	38.1	34.5	34.72
51	25.0	30.8	28.54	26.01	26.0	27.6	31.1	27.5	27.72	66	32.5	38.3	36.04	33.51	33.5	35.1	38.6	35.0	35.22
52	25.5	31.3	29.04	26.51	26.5	28.1	31.6	28.0	28.22	67	33.0	38.8	36.54	34.01	34.0	35.6	39.1	35.5	35.72
53	26.0	31.8	29.54	27.01	27.0	28.6	32.1	28.5	28.72	68	33.5	39.3	37.04	34.51	34.5	36.1	39.6	36.0	36.22
54	26.5	32.3	30.04	27.51	27.5	29.1	32.6	29.0	29.22	69	34.0	39.8	37.54	35.01	35.0	36.6	40.1	36.5	36.72
55	27.0	32.8	30.54	28.01	28.0	29.6	33.1	29.5	29.72										

2. P.C.B LAYOUT, TOL: ±0.05

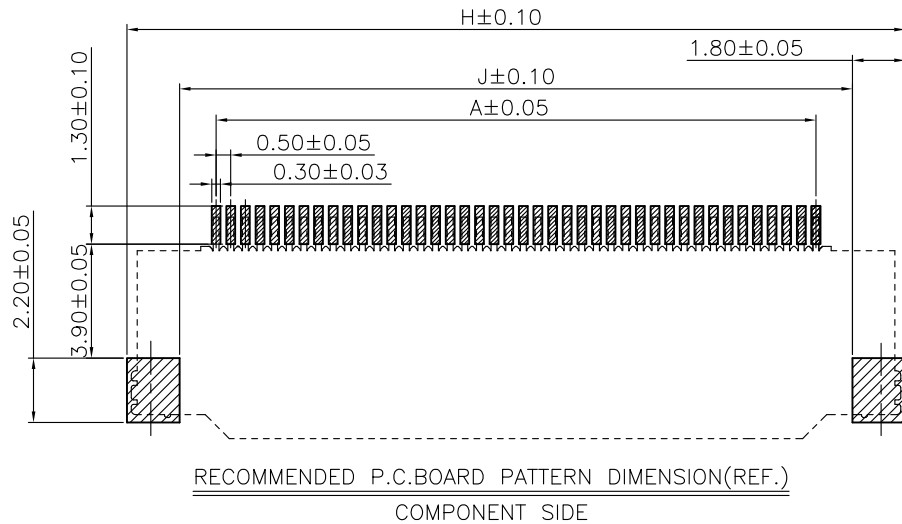

UNLESS OTHERWISE SPECIFIED TOLERANCES		ANGLE OF PROJECTION			
X.	±0.50	X. °	± 1°		
X.X	±0.25	X.X °	± 0.5°	DOC TYP Customer Drw	TITLE: Assembly Drawing For 0.5mm pitch Front side filp, with lock,H2.55mm(41~69PIN)
X.XX	±0.15	X.XX °	± 0.5°		
X.XXX	±0.10	X.XXX °	± 1°	DRAWN DATE Sam 2017-03-27	SIZE DWG NO. A4 A-S0083
LINEAR DIMS		ANGLES DIMS		DESIGN DATE Sam 2017-03-27	REV. G
P/N: HRS-F31L-1*7*1-110** HRS-F31L-1*7*1-110**-E*20		MATERIAL SEE NOTES		CHECKED DATE Jason 2017-03-27	SCALE 1:1
FINISHED SEE NOTES		APPROVED DATE Frank 2017-03-27		SHEET 2 OF 2	

1. 适用范围 Scope:

此作业规范适用于: 0.5/1.0Pitch FPC/FFC CONN.ZIF R/A SMT H=2.55 掀盖式

This product specifications is applied for: 0.5/1.0 FPC/FFC CONN.ZIF R/A H=2.55 Lift cover type

与 FPC/FFC 连接方式 Connected to the FPC/FFC : ZIF

FPC/FFC 适合厚度 FPC/FFC is suitable for thickness : 0.30±0.03mm

2. 关联规格 Related specifications:

EIA-364 : 电子连接器及接插件测试程序 Electronic connectors and connector test procedure

UL STD-94 : 关于塑材设备零配件及器材阻燃性测试规范 On the plastic material and equipment spare parts and equipment flame retardancy test specification

3. 构造 尺寸 材料 Configurations dimensions and materials :

参见结构图 Reference the drawing.

序号 No.	部 位 Position	原材料供应商 material suppliers	材料名/Type名 Materials	防火等级 FLAME CLASS	UL 编号 FILE NO.
1	主体 (HOUSING)	宝理 POLYPLASTICS CO., LTD	LCP Liquid crystal polymer	V-0	E106764
2	掀盖 (ACTUATOR)	可乐丽 KURARAY CO., LTD	PA9T Polyamide 9T	V-0	E90350

4. 标准状态:

4.1 额定电压 Rating voltage: AC/DC 50V

4.2 额定电流 Rating current: 0.5A

4.3 温湿度范围 Temperature and humidity range

4.3.1 使用温度范围 operation temperature: -40℃~+105℃;

4.3.2 储存温度范围 storage temperature: -40℃~+105℃;

4.3.3 开封使用温度范围 Kaifeng temperature range: +5℃~+35℃;

开封使用湿度 Kaifeng Humidity: 60%RH MAX.

4.3.4 保存湿度范围 Keep humidity range:

相对湿度 Relative humidity: 45~80%RH.

5. 性能 Performance
5.1 构造 Structure

序号 NO.	项 目 Item	测试方法 Test conditions	规格要求 Specifications
1	外观 Appearance	目视 Visual	无损坏 No physical damage

5.2 电气性能 Electrical Performance

序号 NO.	项 目 Item	测试方法 Test conditions	规格要求 Specifications
1	接触阻抗 Contact Resistance	适配 FFC 标准线, 开放电压: 20mV 以下, 短路电流: 10mA 以下 Mate applicable FPC, measure by dry circuit, 20mV MAXIMUM, 10mA MAXIMUM	30mΩ Max.
2	绝缘阻抗 Insulation Resistance	相邻端子间 DC 500V, 1 分钟。 DC 500V between adjacent terminals, 1 minutes	500MΩ Min.
3	耐电压 Dielectric withstanding voltage	相邻端子间 AC 500V, 感度电流 2mA, 1 分钟。 AC 500V between adjacent terminals, sensitivity of current 2mA, 1 minutes	无击穿, 无短路 No Breakdown.
4	温度上升 Temperature rise	端子在额定电压·电流下工作时测量端子上升的温度 The rising temperature measurement terminal terminal at rated current under.	30℃ max

本制品不含 SS-00259 和 ROHS 禁止使用的环境物质

This product does not contain SS-00259 and ROHS banned the use of environmental substances

制 品 仕 样 书 Product specification		Part name	0.5/1.0 FPC/FFC CONN.ZIF R/A H=2.55 Lift cover type (H=2.55 掀盖式)		
 瑞澤電子股份有限公司 Horustech Electronics Co., Ltd		Part No.	HRS-F31L-1*7*1-10** HRS-F51L-1*7*1-10** HRS-F31L-1*7*1-10**-E**0 HRS-F51L-1*7*1-10**-E**0 HRS-F33G-1*7*1-10**-E**0	1/6	
		Document No. : IS.EQC.039	Date: 2016/09/22	Rev. : F	Written by Sam

5.3 机械性能 Mechanical performance

序号 NO.	项目 Item	测试方法 Test conditions	规格要求 Specifications
1	FFC/FPC 保持力 FFC/FPC Retention Force	FFC/FPC(标配厚度 0.30mm)插入 FPC 连接品后, 压合掀盖, 打开掀盖, 此动作重复 3 次后, 以 25~100mm/分匀速垂直拔出。 FFC/FPC (standard thickness of 0.30 mm) after insert FPC connection is tasted, pressing lift cover, opens the cover, the action after repeated three times, vertical pull out at a constant speed to 25 to 100 mm/min.	FFC:40gf~70gf/pin FPC:40gf~75gf/pin
2	端子保持力 Terminal Retention Force	将端子 25~100mm/分匀速垂直从胶芯槽内拔出 Apply axial pull out force on the terminal assembled in the housing at the speed rate of 25~100mm per minute.	100gf/terminal Min.
3	固定片保持力 Anchor-Plate Retention Force	将固定片 25~100mm/分匀速垂直从胶芯槽内拔出 Apply axial pull out force on the Anchor-Plate assembled in the housing at the speed rate of 25~100mm per minute.	100gf/terminal Min.
4	掀盖动用力 (高温后不装皮线) Actuator Force (Do not install FFC)	主体内不插入 FFC, 测量掀盖下压和拔起的作用力, 此动作重复三次后, 第四次才作测量数据的记录。 Do not Insert the FFC line into the main body, measure the cover Under pressure and withdraw the force, This action was repeated three times, fourth times for data recording	掀盖压入力 Cover pressing force: 500gf Max. 掀盖拔出力 Cover withdraw force: 40gf Min.
	掀盖动用力 (高温后装皮线) Actuator Force (install FFC)	将 FFC 线插入主体, 测量掀盖下压和拔起的作用力, 此动作重复三次后, 第四次才作测量数据的记录。 Insert the FFC line into the main body, measure the cover Under pressure and withdraw the force, This action was repeated three times, fourth times for data recording	掀盖压入力 Cover pressing force: 1500gf Max. 掀盖拔出力 Cover withdraw force: 150gf Min.
5	插拔耐久性 Durability	以下动作进行 30 次巡回: FPC 插入、掀盖压入、掀盖拔起、FPC 拔出 The following action 30 Tour FPC insert ,Cover Under pressure, cover withdraw, FPC withdraw	接触阻抗 Contact Resistance: 50mΩ Max 无异常 No abnormal appearance

5.4 环境性能和其它 Environmental Performance and Others

序号 NO.	项目 Item	测试方法 Test conditions	规格要求 Specifications
1	耐振性 Vibration	配合合适的 FPC, 按以下条件, X、Y、Z 方向各 2 小时, 共 6 小时在测试过程中通过直流 1mA, 振幅 1.5mm, 频率 10~55~10Hz/分。 Mate applicable FPC, according to the following conditions, X, Z, Y direction of each 2 hours, a total of 6 hours passing DC 1mA during the test. Amplitude: 1.5mm P-P Frequency: 10~55~10 Hz Shall be traversed in 1 minute.	接触阻抗 50mΩ Max. Contact Resistance: 50mΩ Max.
2	耐冲击性 Shock	配合合适的 FPC, 按以下条件, X,Y,Z 方向各 11ms, 各 3 回, 共 18 回, 在测试过程中通过直流 1mA, 加速度 490m/s ² , Mate applicable FPC ,according to the following conditions, X, Z, Y direction of the 11ms, the 3 times, a total of 18 times during the test process by DC 1mA. Test pulse : Half Sine Peak value : 490m/s2 {50G} Duration : 11 milliseconds	瞬断 1μs 以内; Discontinuity: 1μs Max. 外观无异常 No abnormal appearance
3	耐寒性 Cold Resistance	配合合适的 FPC, -40±3℃中放置时间 96H 后取出, 1~2 小时常温放置后进行测试。 Mate applicable FPC , after -40±3℃, the time of 96H was removed, and the test was conducted at room temperature for 1~2 hours.	1. 接触阻抗: 50mΩ Max. 2. 绝缘阻抗: 500 MΩ Min. 3. 耐电压: 无击穿, 短路 4. 外观: 无异常
4	耐热性 Heat Resistance	配合合适的 FPC, 105 ± 2℃中放置时间 96H 后取出, 1~2 小时常温放置后进行测试。 Mate applicable FPC , after 105±2℃, the time of 96H was removed, and the test was conducted at room temperature for 1~2 hours.	1. Contact Resistance: 50mΩ Max. 2. Insulation Resistance : 500 MΩ Min.
5	耐湿性 Humidity	配合合适的 FPC, 60±3℃、相对湿度 90~95%中放置时间 96H 后取出, 1~2 小时常温放置后进行测试。 Mate applicable FPC , 60±3℃, relative humidity 90~95% in the time of 96H after removal, 1~2 hours after room temperature for testing.	3. Dielectric withstanding voltage: No Breakdown. 4. No abnormal appearance

本制品不含 SS-00259 和 ROHS 禁止使用的环境物质

This product does not contain SS-00259 and ROHS banned the use of environmental substances

制品仕様书 Product specification		Part name	0.5/1.0 FPC/FPC CONN. ZIF R/A H=2.55 Lift cover type(H=2.55 掀盖式)		
 瑞澤電子股份有限公司 Horustech Electronics Co., Ltd		Part No.	HRS-F31L-1*7*1-*10** HRS-F51L-1*7*1-*10** HRS-F31L-1*7*1-*10**-E**0 HRS-F51L-1*7*1-*10**-E**0 HRS-F33G-1*7*1-*10**-E**0	2/6	
		Document No. : IS.EQC.039	Date: 2016/09/22	Rev. : F	Written by: Sam

序号 NO.	项目 Item	测试方法 Test conditions	规格要求 Specifications												
6	盐雾试验 Salt Spray	配合合适的 FPC，温度 35±2℃；盐水比重 5±1% 喷雾试验，试验后常温水洗干燥后进行测试。 A: 镀金 48h B: 镀锡 24h C: 单 pin 端子 48h Mate applicable FPC, the temperature of 35±2℃, the proportion of salt water was 5±1% the test was carried out at room temperature after washing and drying. A: gold plating 48H B: tin 24h C: single pin terminal 48H	1. 接触阻抗: 50mΩ Max. 2. 绝缘阻抗: 500 MΩ Min. 3. 耐电压: 无击穿, 短路 4. 外观: 无异常												
7	冷热冲击 Thermal Shock	配合合适的 FPC，-55±3℃；85±2℃ 的温度下各放置 30 分钟，共进行 5 次循环 Mate applicable FPC, -55±3℃, 85±2℃, 30 minutes, 5 cycles were performed. 1: -55℃ 30 minutes 2: +85℃ 30 minutes	1. Contact Resistance: 50mΩ Max. 2. Insulation Resistance :500 MΩ Min. 3. Dielectric withstanding voltage: No Breakdown. 4. No abnormal appearance												
8	耐湿性 (温湿度循环) Humidity (Temperature and Humidity Cycle)	配合合适的 FPC，依照下面曲线完成 5 次循环试验。 Mate applicable FPC, complete the 5 cycle test according to the curve below. 	1. Contact Resistance: 50mΩ Max. 2. Insulation Resistance :500 MΩ Min. 3. Dielectric withstanding voltage: No Breakdown. 4. No abnormal appearance												
9	沾锡性 Solderability	端子焊脚和固定片前端 0.3mm，沾锡温度 245±5℃ (Sn: Lead Free); 时间 3± 0.5S Terminal welding feet and fitting nail front 0.3mm, soldering temperature 245±5℃ (Sn: Lead Free); time 3±0.5S	吃锡饱满，在 95% 以上 95% of immersed area must show no voids, pin holes												
10	焊锡耐热性 Resistance to Soldering Heat	端子焊脚和固定片前端 0.3mm，烙铁温度 350±10℃ (Sn: Lead Free); 时间 10+1/-0 S Terminal welding feet and fitting nail front 0.3mm, soldering Iron temperature 350±10℃ (Sn: Lead Free), time: 10+1/-0 S	外观无异常， No abnormal appearance												
11	Reflow	预备加热时间 Pre-heating time: 170℃~190℃ 60~180s。 焊锡温度时间 Soldering Temperature Time: 260℃ 10sMAX。	共面度 0.10mm Max. 外观无异常， Coplanar degree 0.10mm Max. No abnormal appearance.												
12	耐硫化性 (镀金品) Sulfidation resistance (Gold)	满足三种混合气体的试验的要求 Meet the requirements of the test of three kinds of mixed gas <table border="1" data-bbox="422 1332 1109 1422"> <thead> <tr> <th>H₂S</th> <th>NO₂</th> <th>SO₂</th> <th>Temperature</th> <th>Humidity</th> <th>Time</th> </tr> </thead> <tbody> <tr> <td>0.5ppm</td> <td>1.0ppm</td> <td>1.0ppm</td> <td>35℃</td> <td>70%RH</td> <td>72H</td> </tr> </tbody> </table>	H ₂ S	NO ₂	SO ₂	Temperature	Humidity	Time	0.5ppm	1.0ppm	1.0ppm	35℃	70%RH	72H	接触阻抗: 50mΩ Max. Contact Resistance 50mΩ Max. 触点附近无明显腐蚀。 Nearby contact no significant corrosion
H ₂ S	NO ₂	SO ₂	Temperature	Humidity	Time										
0.5ppm	1.0ppm	1.0ppm	35℃	70%RH	72H										
13	Whisker (Tin 镀锡品)	过 reflow 后插入 FPC，放置 500H，观察 WHISKER 的长度 Insert FPC after reflow, place 500H, observe the length of Whisker	100um max												
14	耐溶剂 Solvent	将产品放入异丙基酒精容器中 90 秒后取出。Product into the isopropyl alcohol container removed after 90 seconds.	满足电气性能， 外观无异常。 Meet electrical performance No abnormal appearance.												

本制品不含 SS-00259 和 ROHS 禁止使用的环境物质

This product does not contain SS-00259 and ROHS banned the use of environmental substances

制品仕様書 Product specification	Part name	0.5/1.0 FPC/FFC CONN. ZIF R/A H=2.55 Lift cover type (H=2.55 掀盖式)			
 瑞澤電子股份有限公司 Horustech Electronics Co., Ltd	Part No.	HRS-F31L-1*7*1-*10** HRS-F51L-1*7*1-*10** HRS-F31L-1*7*1-*10**-E**0 HRS-F51L-1*7*1-*10**-E**0 HRS-F33G-1*7*1-*10**-E**0	3/6		
Document No.: IS.EQC.039	Date: 2016/09/22	Rev.: F	Written by: Sam	Checked by: Jason	Approved by: Frank

6. 包装 Packing

参见捆包图。See the drawing

7. 修改内容 Change content

版本 Rev.	改正日期 Modify date	改正内容 Modifications	Written by	Checked by
A	2013/05/23	New	王梅芳	Rain
B	2016/01/12	新增料号	王梅芳	Rain
C	2016/04/06	修改接触电阻参数,更新 FFC 保持力标准为 40gf/PIN MIN Modify contact resistance parameters, Update the FFC retention standard for 40gf/PIN MIN	May	Rain
D	2016/04/20	新增规格 To increase the new specifications	May	Rain
E	2016/5/13	新增料号	May	Rain
F	2016/9/22	更新 FFC/FPC 保持力测试方法及更新 Reflow 温度条件; 新增料号	May	Rain

Reflow Condition:

Profile Feature	Sn-Pb Eutectic Assembly
温度上升 (Ramp up Rate(Tsmax to Tp)	:1~4°C/S
. Pre-heat Ts MIN. Ts MAX. Time(Ts MIN. TO Ts MAX.)	:170°C MIN :190°C MAX :60~180S
T l 温度 (temperature) 时间 (time)	:225°C MIN :60~150S
T p (Peak) 温度 (temperature) 时间 (time)	:260°C MAX(255°C MIN.) :10S MAX

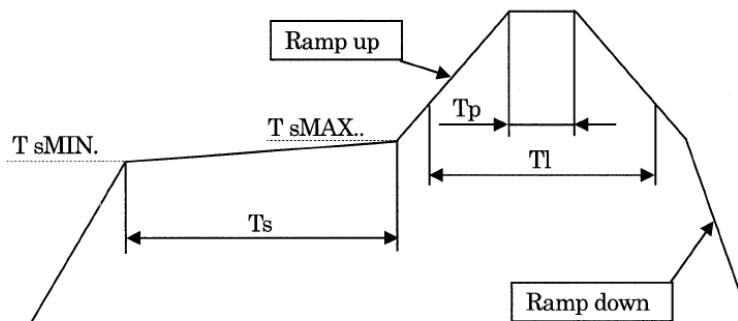

本制品不含 SS-00259 和 ROHS 禁止使用的环境物质

This product does not contain SS-00259 and ROHS banned the use of environmental substances

制品仕様书 Product specification	Part name	0.5/1.0 FPC/FFC CONN. ZIF R/A H=2.55 Lift cover type (H=2.55 掀盖式)			
 瑞澤電子股份有限公司 Horustech Electronics Co., Ltd	Part No.	HRS-F31L-1*7*1-10** HRS-F51L-1*7*1-10** HRS-F31L-1*7*1-10**-E**0 HRS-F51L-1*7*1-10**-E**0 HRS-F33G-1*7*1-10**-E**0	4/6		
	Document No. : IS.EQC.039	Date: 2016/09/22	Rev. : F	Written by: Sam	Checked by: Jason

操作说明和注意事项 Operating instructions and matters needing attention

1): FFC 插入方法: 打开, 关闭掀盖, 请在连接器装在电路板上的状态下实施; 将掀盖向上推, 以解除锁定, 靠人的食指和拇指甲向上拨动, 可以很简单的操作。

1) FFC insertion method: open, lift off cover, Please implement in the connector arranged on the circuit board of the state; will cover up, to release the lock, on the forefinger and thumb nail to pull, can be very simple to operate.

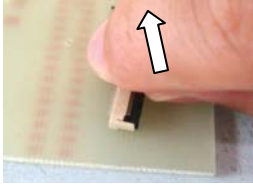

4): 拔出 FFC 的方法; 依照 1 的方法进行打开掀盖; 在拔出 FFC 时, 请在掀盖完全打开的状态下进行. 万一在掀盖未完全打开的状态下, 拔出 FFC, 重新装入 FFC 时, 请确认触点部位是否有附着物。

4): Pull out the FFC method; open the lift cover in accordance with the 1 method; in the case of the FFC, please open the cover is completely opened. In case of the cover is not fully open, pull out FFC, re FFC, please confirm whether the contact part of the attached

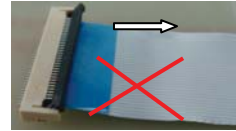

2): 插入 FFC 时, 请在掀盖完全打开的状态下进行, FFC 的导体面朝下, FPC 相对于连接器垂直插入, 要确认 FFC 插到顶住本体的底部. 本产品在设计上, 掀盖张开不能超过 100°, 所以在后部不要施加超出此范围的力, 否则掀盖会松脱或破损。

2): When FFC is inserted, the FFC is turned on, the FFC is facing down, and the FPC is inserted into the bottom of the body. This product is in the structural design, and the lift cover is not more than 100 degrees, so it is not applied to the rear

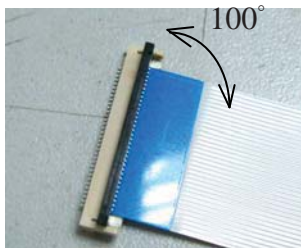

5): 对 FFC, 请在其上方不要施加拉力, 或在其端子间距方向施加撬动力

5): On FFC, please do not apply a pull on the top of it, or force the direction of the terminal spacing.

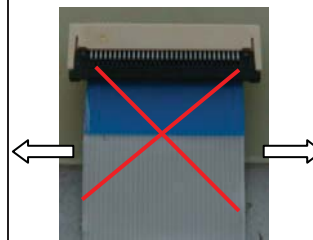
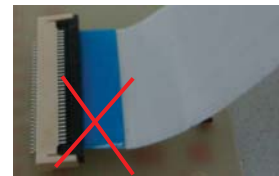

3): 向下按掀盖的中间部位, FFC 半插入、或插入错位极大时, 掀盖的卡住状态不佳, 会浮起. 此时, 要按 4) 的拔出方法取出 FFC, 再次从 1) 开始操作. 同时, 进行锁定作业时, 要固定好连接器。

3): Down by the middle part of the lift cover, FFC semi insert, or insert a great when the lift cover of the stuck state is not good, will float. At this point, to press 4) to remove the FFC, again from the beginning of 1) operation. At the same time, when the lock operation, to fix the connector

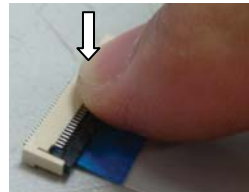
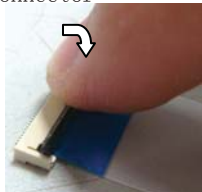

6): 请避免用手指捏或拔掀盖 (特别是用指甲拨动) 等的操作

6): Please do not use your fingers to pinch or pull off the cover (especially with the nail), and so on.

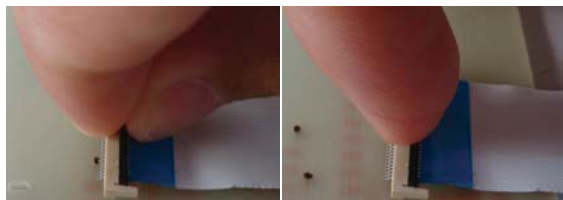

本制品不含 SS-00259 和 ROHS 禁止使用的环境物质

This product does not contain SS-00259 and ROHS banned the use of environmental substances

制品仕様书 Product specification		Part name	0.5/1.0 FPC/FFC CONN. ZIF R/A H=2.55 Lift cover type (H=2.55 掀盖式)		
 瑞澤電子股份有限公司 Horustech Electronics Co., Ltd		Part No.	HRS-F31L-1*7*1-*10** HRS-F51L-1*7*1-*10** HRS-F31L-1*7*1-*10**-E**0 HRS-F51L-1*7*1-*10**-E**0 HRS-F33G-1*7*1-*10**-E**0	5/6	
Document No.: IS.EQC.039	Date: 2016/09/22	Rev.: F	Written by: Sam	Checked by: Jason	Approved by: Frank

操作说明和注意事项 Operating instructions and matters needing attention

7): 请将 FFC 正确地插入连接器的插入口. 要确认 FFC 插到顶住本体的底部, 如果不正确的插入, 会导致短路, 导通不良. 插入 FFC 时, 不要用力擦蹭连接器插入口的下面, 否则端子会与 FFC 强烈碰撞, 导致端子变形, FFC 导体剥落等的不良.

Please insert the FFC into the connector correctly. Insert the FFC into the bottom of the body. If not properly inserted, the FFC will be short. If you insert a FFC, don't rub the connector into the mouth.

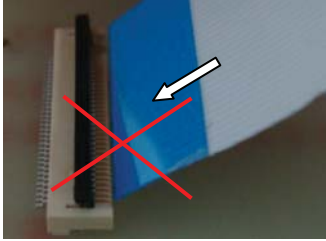

8): 如果是大 PIN 数的时候请按盖子的两端进行关闭.

8): If it is a large PIN number, please press the two ends of the cover to be closed.

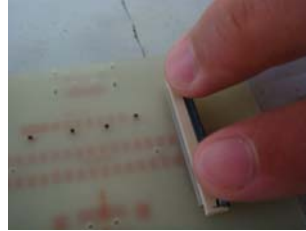

本制品不含 SS-00259 和 ROHS 禁止使用的环境物质

This product does not contain SS-00259 and ROHS banned the use of environmental substances

制品仕様书 Product specification		Part name	0.5/1.0 FPC/FFC CONN. ZIF R/A H=2.55 Lift cover type (H=2.55 掀盖式)	
 瑞澤電子股份有限公司 Horustech Electronics Co., Ltd		Part No.	HRS-F31L-1*7*1-*10** ; HRS-F51L-1*7*1-*10** HRS-F31L-1*7*1-*10**-E**0 HRS-F51L-1*7*1-*10**-E**0 HRS-F33G-1*7*1-*10**-E**0	6/6
Document No. : IS.EQC.039	Date: 2016/09/22	Rev. : F	Written by: Sam	Checked by: Jason Approved by: Frank